

**FX2N-4AD SPECIAL FUNCTION BLOCK**

**USER'S GUIDE**

JY992D65201E

# FX2N

This manual contains text, diagrams and explanations which will guide the reader in the correct installation and operation of the FX2N-4AD and should be read and understood before attempting to install or use the unit.

Further information can be found in the FX SERIES PROGRAMMING MANUAL(II), FX0N/FX1N/FX2N/FX2NC/FX3U/FX3UC SERIES HARDWARE MANUAL.

## Guidelines for the Safety of the User and Protection of the FX2N-4AD special function block.

This manual should be used by trained and competent personnel. The definition of such a person or persons is as follows:

- Any engineer using the product associated with this manual, should be of a competent nature, trained and qualified to the local and national standards. These engineers should be fully aware of all aspects of safety with regards to automated equipment.
- Any commissioning or service engineer must be of a competent nature, trained and qualified to the local and national standards.
- All operators of the completed equipment should be trained to use this product in a safe and coordinated manner in compliance to established safety practices.

**Note:** The term 'completed equipment' refers to a third party constructed device which contains or uses the product associated with this manual.

### Notes on the Symbols Used in this Manual

At various times throughout this manual certain symbols will be used to highlight points of information which are intended to ensure the users personal safety and protect the integrity of equipment.



- 1) Indicates that the identified danger **WILL** cause physical and property damage.



- 2) Indicates that the identified danger could **POSSIBLY** cause physical and property damage.

- Under no circumstances will Mitsubishi Electric be liable or responsible for any consequential damage that may arise as a result of the installation or use of this equipment.
- All examples and diagrams shown in this manual are intended only as an aid to understanding the text, not to guarantee operation. Mitsubishi Electric will accept no responsibility for the actual use of the product based on these illustrative examples.
- Owing to the very great variety in possible application for this equipment, you must satisfy yourself as to its suitability for your specific application.

## 1. INTRODUCTION

- The FX2N-4AD analog special function block has four input channels. The input channels receive analog signals and convert them into a digital value. This is called an A/D conversion. The FX2N-4AD has maximum resolution of 12 bits.
- The selection of voltage or current based input/output is by user wiring. Analog ranges of -10 to 10V DC (resolution: 5mV), and/or 4 to 20mA, -20 to 20mA (resolution: 20 μA) may be selected.
- The FX2N-4AD can be connected to the FX0N/FX1N/FX2N/FX2NC/FX3U/FX3UC series Programmable Controllers (PLC).
- Data transfer between the FX2N-4AD and the main unit is by buffer memory exchange. There are 32 buffer memories (each of 16 bits) in the FX2N-4AD.
- The FX2N-4AD occupies 8 I/O points on the FX2N expansion bus. The 8 I/O points can be allocated from either inputs or outputs. The FX2N-4AD draws 30mA from the 5V rail of the main unit or powered extension unit.

## 2. EXTERNAL DIMENSIONS

Weight : Approx. 0.3 kg (0.66 lbs)    Dimensions : mm (inches)

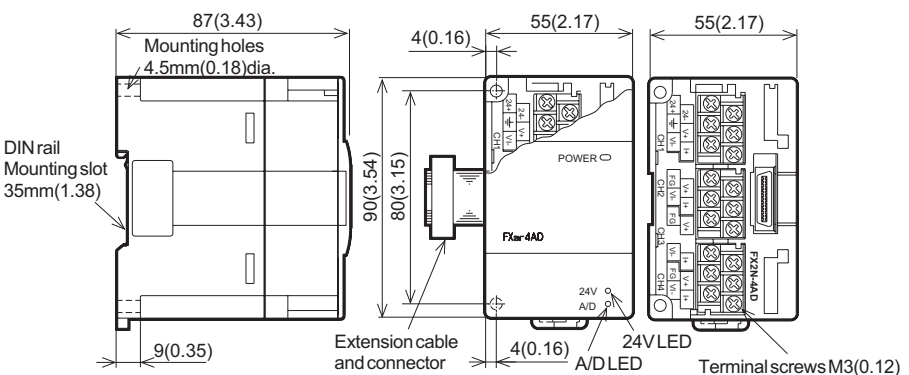

### 3. WIRING

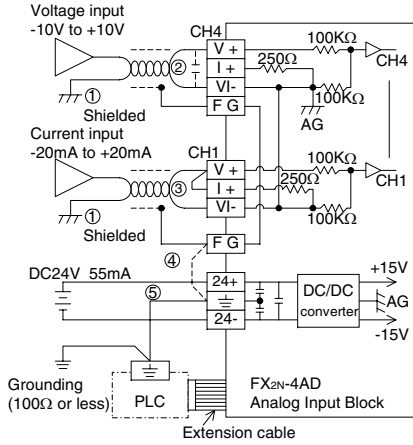

- ① The analog input is received through a twisted pair shielded cable. This cable should be wired separately from power lines or any other lines which may induce electrical noise.
- ② If a voltage ripple occurs during input, or there is electrically induced noise on the external wiring, connect a smoothing capacitor of 0.1 to 0.47  $\mu\text{F}$ , 25V.
- ③ If you are using current input, connect the V+ and I+ terminals to each other.
- ④ If there is excessive electrical noise, connect the FG (frame ground) terminal with the grounded terminal on the FX2N-4AD. (In CH1, there is no FG terminal. Use FG terminal of other channels.)
- ⑤ Connect the ground terminal on the FX2N-4AD unit with the grounded terminal on the main unit. Use grounding on the main unit, if available.

### 4. CONNECTION WITH PLC

The FX2N-4AD unit can be connected to the PLCs as follows. Restrictions apply to the maximum number of connectable units, depending on the DC24V/DC5V Power Supply capacities and the Main Unit/Special Function Unit types. For details, refer to the respective PLC manual.

FX2N/FX3U : The maximum connectable units is 8.

FX3UC\*1 : The maximum connectable units is 8.

To connect the FX2N-4AD with the FX3UC main unit, FX2NC-CNV-IF or FX3UC-1PS-5V is required.

FX2NC : The maximum connectable units is 4.

To connect the FX2N-4AD with the FX2NC main unit, FX2NC-CNV-IF is required.

FX1N : The maximum connectable units is 8.

FX0N : The maximum connectable units is 4.

\*1 Up to 7 units can be connected to an FX3UC-32MT-LT PLC.

### 5. SPECIFICATIONS

#### 5.1 General specification

Item	Specification
General specifications	Same as those for the main unit
Dielectric withstand voltage	500V AC, 1min (between all terminals and ground)

#### 5.2 Performance specification and others

Item	Specification
Analog circuits	24V DC $\pm$ 10%, 55mA (external power supply from the main unit)
Digital circuits	5V DC, 30mA (internal power supply from main unit)
Isolation	Photo-coupler isolation between analog and digital circuits. DC/DC converter isolation of power from the main unit. No isolation between analog channels.
Number of occupied I/O points	The analog block occupies 8 points. (can be either inputs or outputs)

### 5.3 Performance specification

#### Analog Inputs

Item	Voltage input	Current input
		Either voltage or current input can be selected with your choice of input terminal. Up to four input points can be used at one time.
Analog input range	DC -10V to +10V (input resistance: 200kΩ). Warning: this unit may be damaged by an input voltage in excess of ± 15V.	DC -20mA to +20mA (input resistance: 250Ω). Warning: this unit may be damaged by an input currents in excess of ± 32mA.
Digital output	12-bit conversion stored in 16-bit 2's complement form. Maximum value: +2047 Minimum value: -2048	
Resolution	5mV (10V default range 1/2000)	20μA (20mA default range 1/1000)
Overall accuracy	± 1% (for the range of -10V to +10V)	± 1% (for the range of -20mA to +20mA)
Conversion speed	15ms/channel (Normal speed), 6ms/channel (High speed)	

#### Analog Inputs continued...

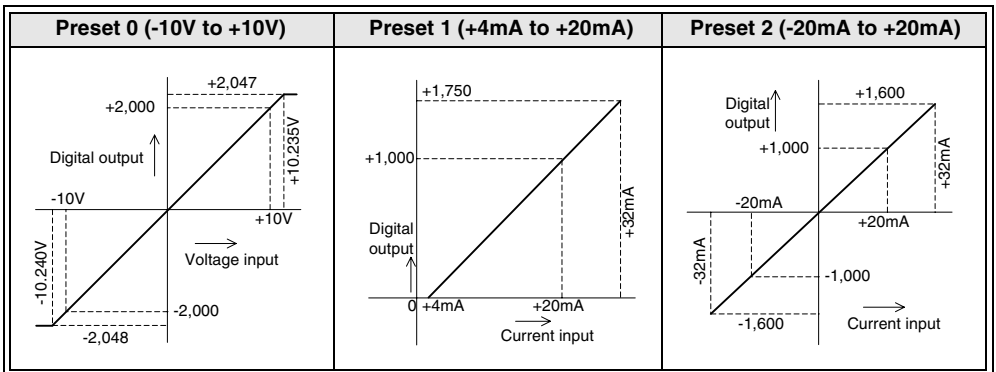

NOTE: Preset ranges are selected by an appropriate setting in the buffer memory of the analog block. Current/Voltage input selection must match the correct input terminal connections.

## 6. ALLOCATION OF BUFFER MEMORIES (BFM#)

### 6.1 Buffer memories

BFM	Contents								
*#0	Channel selection Default = H0000								
*#1	Channel 1	Contains the number of samples (1 to 4096) to be used for an averaged result. The default setting is 8- normal speed. High speed operation can be selected with a value of 1.							
*#2	Channel 2								
*#3	Channel 3								
*#4	Channel 4								
#5	Channel 1	These buffer memories contain the averaged input values for the number of samples entered for the channel in buffer memories #1 to #4 respectively.							
#6	Channel 2								
#7	Channel 3								
#8	Channel 4								
#9	Channel 1	These buffer memories contain the present value currently being read by each input channel.							
#10	Channel 2								
#11	Channel 3								
#12	Channel 4								
#13 - #14	Reserved								
#15	Selection of A/D conversion speed see note 2	When set to 0, a normal speed is selected of 15ms/ch (default)							
		When set to 1, a high speed is selected of 6ms/ch							
#16 - #19	Reserved								
*#20	Reset to Defaults and Preset.	Default = 0							
*#21	Offset, Gain Adjust Prohibit.	Default = (0, 1) Permit							
*#22	Offset, Gain Adjust	b7	b6	b5	b4	b3	b2	b1	b0
		G4	O4	G3	O3	G2	O2	G1	O1
*#23	Offset Value	Default = 0							
*#24	Gain Value	Default = 5,000							
#25 - #28	Reserved								
#29	Error status								
#30	Identification code K2010								
#31	Cannot be used								

In buffer memory locations (BFMs) marked with an “\*” data can be written from the PLC using the TO instruction.

For buffer memories (BFMs) without “\*” mark, data can be read by the PLC using the FROM instruction.

Before reading from the analog special function block, ensure that the appropriate settings have been sent to the analog special function block. Otherwise, the previous values held in the analog block will be used.

The buffer memory also gives a facility to adjust the offset and gain via software.

Offset (intercept): The analog input value when the digital output becomes 0.

Gain (slope): The analog input value when the digital output becomes +1000.

#### 1) Channel Selection

Channel selection is made by a 4 character HEX number HOOOO in buffer memory BFM #0. The least significant character controls channel 1 and the 4th character controls channel 4.

Setting of each character is as follows:

- |                                     |                                      |
|-------------------------------------|--------------------------------------|
| O = 0: Preset range (-10V to +10V)  | O = 2: Preset range (-20mA to +20mA) |
| O = 1: Preset range (+4mA to +20mA) | O = 3: Channel OFF                   |

Example: H3310

- CH1 : Preset range (-10V to +10V)  
 CH2 : Preset range (+4mA to +20mA)  
 CH3, CH4: Channel OFF

#### 2) Analog to Digital Conversion Speed Change

By writing 0 or 1 to BFM #15 of the FX2N-4AD, the speed at which A/D conversion is performed can be changed.

However the following points should be noted:

To maintain a high speed conversion rate, use the FROM/TO instructions as seldom as possible.

NOTE: When a conversion speed change is made, BFM #1-#4 are set to their default values immediately after the change. This is regardless of the values they held originally. Bear this in mind if a speed change will be made as part of the normal program execution.

#### 3) Adjusting Gain and Offset values

- When buffer memory BFM #20 is activated by setting it to K1, all settings within the analog special function block are reset to their default settings. This is a very quick method to erase any undesired gain and offset adjustments.
- If (b1, b0) of BFM #21 is set to (1,0), gain and offset adjustments are prohibited to prevent inadvertent changes by the operator. In order to adjust the gain and offset values, bits (b1, b0) must be set to (0,1). The default is (0,1).
- Offset and gain values of BFM #23 and #24 are sent respectively to the offset and gain registers in non-volatile memory of the specified input channels. Input channels to be adjusted are specified by the appropriate G-O (gain-offset) bits of BFM #22.  
 Example: If bits G1 and O1 are set to 1, input channel 1 will be adjusted when BFM #22 is written to by a TO instruction.
- Channels can be adjusted individually or together with the same gain and offset values.
- Offset and gain values in BFM #23 and #24 are in units of mV or mA. Due to the resolution of the unit the actual response will be in steps of 5mV or 20 mA.

#### 4) Status Information BFM #29

Bit devices of BFM #29	ON	OFF
b0 : Error	When any of b1 to b4 is ON. If any of b2 to b4 is ON, A/D conversion of all the channels is stopped.	No error
b1 : Offset/gain error	Offset/Gain data in the EEPROM is corrupted or adjustment error.	Offset/Gain data normal
b2 : Power source abnormality	24V DC power supply failure.	Power supply normal
b3 : Hardware error	A/D converter or other hardware failure.	Hardware Normal
b10 : Digital range error	Digital output value is less than -2048 or more than +2047	Digital output value is normal.
b11 : Averaging error	Number of averaging samples is 4097 or more or 0 or less (default of 8 will be used)	Averaging is normal. (between 1 and 4096)
b12 : Offset/gain adjust prohibit	Prohibit-(b1, b0) of BFM #21 is set to (1, 0)	Permit-(b1, b0) of BFM #21 is set to (0,1)

NOTE: b4 to b7, b9 and b13 to b15 are undefined.

## 5) Identification Code BFM #30

The identification (or ID) code number for a Special Function Block is read using the FROM instruction.

This number for the FX2N-4AD Special Function Block unit is K2010.

The user's program in the PLC can use this facility in the program to identify the special function block before commencing data transfer from and to the special function block.



### CAUTION

- Values of BFM #0, #23 and #24 are copied to the EEPROM memory of the FX2N-4AD. BFM #21 and BFM #22 are only copied when data is written to the gain/offset command buffer BFM #22. Also, BFM #20 causes the resetting of the EEPROM memory. The EEPROM has a life of about 10,000 cycles (changes), so do not use programs which frequently change these BFMs.
- Due to the time needed to write to the EEPROM memory, a delay of 300 ms is required between instructions that cause a write to the EEPROM. Therefore, a delay timer should be used before writing to the EEPROM for a second time.

## 7. DEFINING GAIN AND OFFSET

### Gain

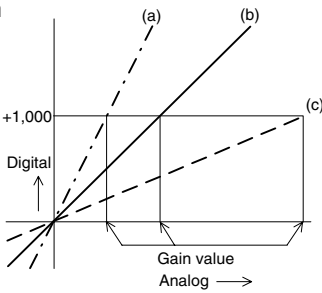

### Offset

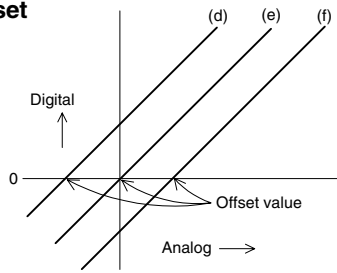

Gain determines the angle or slope of the calibration line, identified at a digital value of 1000.

- Small gain value: Large steps in digital readings
- Zero gain value: default (5V or 20mA)
- Large gain value: Small steps in digital readings

Offset is the 'Position' of the calibrated line, identified at a digital value of 0.

- Negative offset
- Zero offset: default (0V or 4mA)
- Positive offset

Offset and gain can be set independently or together. Reasonable offset ranges are -5V to +5V or -20mA to +20mA, and gain value - offset value = 1V to 15V or 4mA to 32mA. Gain and offset can be adjusted by software in the main unit (see program example 2)

- Bit device's b1, b2 of the gain/offset BFM #21 should be set to 0, 1 to allow adjustment.
- Once adjustment is completed these bit devices should be set to 1, 0 to prohibit any further changes.

## 8. EXAMPLE PROGRAM

### 8.1 Basic Program

In the following example, channels CH1 and CH2 are used as voltage inputs. The FX2N-4AD block is connected at the position of special function block No. 0. The number of averaged samples is set to 4 and data registers D0 and D1 of the main unit receive the averaged digital data.

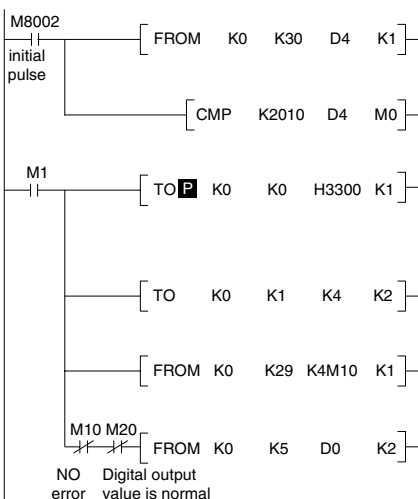

The ID code for the special function block at position "0" is read from BFM #30 of that block and stored at D4 in the main unit.

This is compared with K2010 to check that the block is a FX2N-4AD, if OK M1 is turned ON. These two program steps are not strictly needed to perform an analog read. They are however a useful check and are recommended as good practice.

The analog input channels (CH1, CH2) are setup by writing H3300 to the BFM #0 of the FX2N-4AD.

The number of averaged samples for CH1 and CH2 is set to 4 by writing 4 to the BFM #1 and #2 respectively. Do not execute the pulse form of the instruction.

The operational status of the FX2N-4AD is read from BFM #29 and output as bit devices of the main unit.

If there are no errors in the operation of the FX2N-4AD, then the averaged data BFM's are read. In the case of this example BFM #5 and #6 are read into the main unit and stored in D0 and D1. These devices contain the averaged data for CH1 and CH2 respectively.

## 8.2 Using gain and offset in a program

The following is an example of changing the offset value on input channel CH1 to 0V and the gain value to 2.5V.

The FX<sub>2N</sub>-4AD block is in the position of block No. 0 (i. e. closest to the main unit).

Example: Adjusting gain/offset by PLC programming

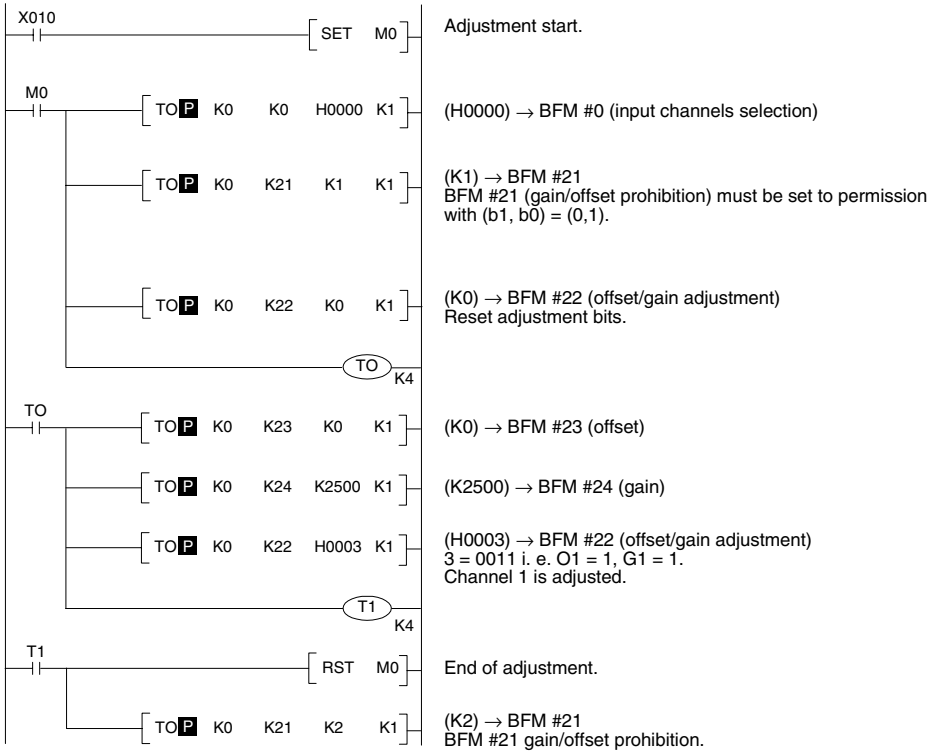

## 9. DIAGNOSTICS

### 9.1 Preliminary checks

- I. Check whether the input wiring and/or extension cables are properly connected on the FX<sub>2N</sub>-4AD analog special function block
- II. Check that the PLC system configuration limits have not been exceeded, i. e. the number of special function blocks, and the total system I/O are within the specified range.
- III. Ensure that the correct operating range has been selected for the application.
- IV. Check that there is no power overload on either the 5V or 24V power sources, remember the loading on a main unit or a powered extension unit varies according to the number of extension blocks or special function blocks connected.
- V. Make sure that the main unit has been switched to RUN.

### 9.2 Error checking

If the FX<sub>2N</sub>-4AD special function block does not seem to operate normally, check the following items.

- Check the status of the POWER LED.  
Lit : The extension cable is properly connected.  
Otherwise : Check the connection of the extension cable.
- Check the external wiring.
- Check the status of the “24V” LED (top right corner of the FX<sub>2N</sub>-4AD).  
Lit : FX<sub>2N</sub>-4AD is OK, 24V DC power source is OK.  
Otherwise : Possible 24VDC power failure, if OK possible FX<sub>2N</sub>-4AD failure.
- Check the status of the “A/D” LED (top right corner of the FX<sub>2N</sub>-4AD).  
Lit : A/D conversion is proceeding normally.  
Otherwise : Check buffer memory #29 (error status). If any bits (b2 and b3) are ON, then this is why the A/D LED is OFF.

This manual confers no industrial property rights or any rights of any other kind, nor does it confer any patent licenses. Mitsubishi Electric Corporation cannot be held responsible for any problems involving industrial property rights which may occur as a result of using the contents noted in this manual.

Manual number : JY992D65201

Manual revision : E

Date : September 2007



HEAD OFFICE : TOKYO BUILDING, 2-7-3 MARUNOUCHI, CHIYODA-KU, TOKYO 100-8310, JAPAN  
HIMEJI WORKS : 840, CHIYODA CHO, HIMEJI, JAPAN

# FX2N

## FX2N-4AD SPECIAL FUNCTION BLOCK

### USER'S GUIDE

JY992D65201E

This manual contains text, diagrams and explanations which will guide the reader in the correct installation and operation of the FX2N-4AD and should be read and understood before attempting to install or use the unit.

Further information can be found in the FX SERIES PROGRAMMING MANUAL(II), FX0N/FX1N/FX2N/FX2NC/FX3U/FX3UC SERIES HARDWARE MANUAL.

### Guidelines for the Safety of the User and Protection of the FX2N-4AD special function block.

This manual should be used by trained and competent personnel. The definition of such a person or persons is as follows:

- Any engineer using the product associated with this manual, should be of a competent nature, trained and qualified to the local and national standards. These engineers should be fully aware of all aspects of safety with regards to automated equipment.
- Any commissioning or service engineer must be of a competent nature, trained and qualified to the local and national standards.
- All operators of the completed equipment should be trained to use this product in a safe and coordinated manner in compliance to established safety practices.

**Note:** The term 'completed equipment' refers to a third party constructed device which contains or uses the product associated with this manual.

#### Notes on the Symbols Used in this Manual

At various times throughout this manual certain symbols will be used to highlight points of information which are intended to ensure the users personal safety and protect the integrity of equipment.



- Indicates that the identified danger **WILL** cause physical and property damage.



- Indicates that the identified danger could **POSSIBLY** cause physical and property damage.

Under no circumstances will Mitsubishi Electric be liable or responsible for any consequential damage that may arise as a result of the installation or use of this equipment.

All examples and diagrams shown in this manual are intended only as an aid to understanding the text, not to guarantee operation. Mitsubishi Electric will accept no responsibility for the actual use of the product based on these illustrative examples.

Owing to the very great variety in possible application for this equipment, you must satisfy yourself as to its suitability for your specific application.

## 1. INTRODUCTION

- The FX2N-4AD analog special function block has four input channels. The input channels receive analog signals and convert them into a digital value. This is called an A/D conversion. The FX2N-4AD has maximum resolution of 12 bits.
- The selection of voltage or current based input/output is by user wiring. Analog ranges of -10 to 10V DC (resolution: 5mV), and/or 4 to 20mA, -20 to 20mA (resolution: 20 μA) may be selected.
- The FX2N-4AD can be connected to the FX0N/FX1N/FX2N/FX2NC/FX3U/FX3UC series Programmable Controllers (PLC).
- Data transfer between the FX2N-4AD and the main unit is by buffer memory exchange. There are 32 buffer memories (each of 16 bits) in the FX2N-4AD.
- The FX2N-4AD occupies 8 I/O points on the FX2N expansion bus. The 8 I/O points can be allocated from either inputs or outputs. The FX2N-4AD draws 30mA from the 5V rail of the main unit or powered extension unit.

## 2. EXTERNAL DIMENSIONS

Weight : Approx. 0.3 kg (0.66 lbs) Dimensions : mm (inches)

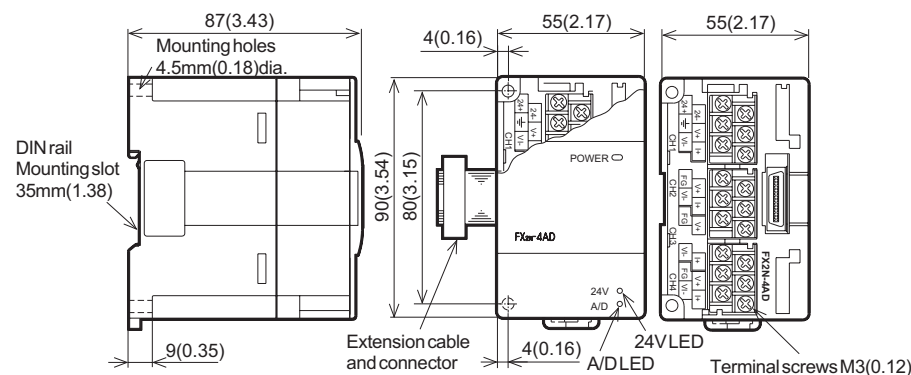

## 3. WIRING

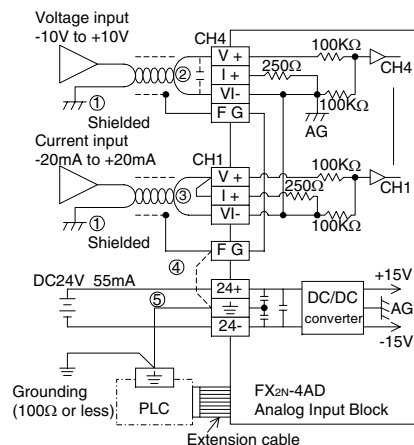

- The analog input is received through a twisted pair shielded cable. This cable should be wired separately from power lines or any other lines which may induce electrical noise.
- If a voltage ripple occurs during input, or there is electrically induced noise on the external wiring, connect a smoothing capacitor of 0.1 to 0.47 μF, 25V.
- If you are using current input, connect the V+ and I+ terminals to each other.
- If there is excessive electrical noise, connect the FG (frame ground) terminal with the grounded terminal on the FX2N-4AD. (In CH1, there is no FG terminal. Use FG terminal of other channels.)
- Connect the ground terminal on the FX2N-4AD unit with the grounded terminal on the main unit. Use grounding on the main unit, if available.

## 4. CONNECTION WITH PLC

The FX2N-4AD unit can be connected to the PLCs as follows. Restrictions apply to the maximum number of connectable units, depending on the DC24V/DC5V Power Supply capacities and the Main Unit/Special Function Unit types. For details, refer to the respective PLC manual.

FX2N/FX3U : The maximum connectable units is 8.

FX3UC\*1 : The maximum connectable units is 8.  
To connect the FX2N-4AD with the FX3UC main unit, FX2NC-CNV-IF or FX3UC-1PS-5V is required.

FX2NC : The maximum connectable units is 4.  
To connect the FX2N-4AD with the FX2NC main unit, FX2NC-CNV-IF is required.

FX1N : The maximum connectable units is 8.

FX0N : The maximum connectable units is 4.

\*1 Up to 7 units can be connected to an FX3UC-32MT-LT PLC.

## 5. SPECIFICATIONS

### 5.1 General specification

Item	Specification
General specifications	Same as those for the main unit
Dielectric withstand voltage	500V AC, 1min (between all terminals and ground)

### 5.2 Performance specification and others

Item	Specification
Analog circuits	24V DC ± 10%, 55mA (external power supply from the main unit)
Digital circuits	5V DC, 30mA (internal power supply from main unit)
Isolation	Photo-coupler isolation between analog and digital circuits. DC/DC converter isolation of power from the main unit. No isolation between analog channels.
Number of occupied I/O points	The analog block occupies 8 points. (can be either inputs or outputs)

## 5.3 Performance specification

### Analog Inputs

Item	Voltage input	Current input
		Either voltage or current input can be selected with your choice of input terminal. Up to four input points can be used at one time.
Analog input range	DC -10V to +10V (input resistance: 200kΩ). Warning: this unit may be damaged by an input voltage in excess of ± 15V.	DC -20mA to +20mA (input resistance: 250Ω). Warning: this unit may be damaged by an input currents in excess of ± 32mA.
Digital output	12-bit conversion stored in 16-bit 2's complement form. Maximum value: +2047 Minimum value: -2048	
Resolution	5mV (10V default range 1/2000)	20μA (20mA default range 1/1000)
Overall accuracy	± 1% (for the range of -10V to +10V) ± 1% (for the range of -20mA to +20mA)	
Conversion speed	15ms/channel (Normal speed), 6ms/channel (High speed)	

### Analog Inputs continued...

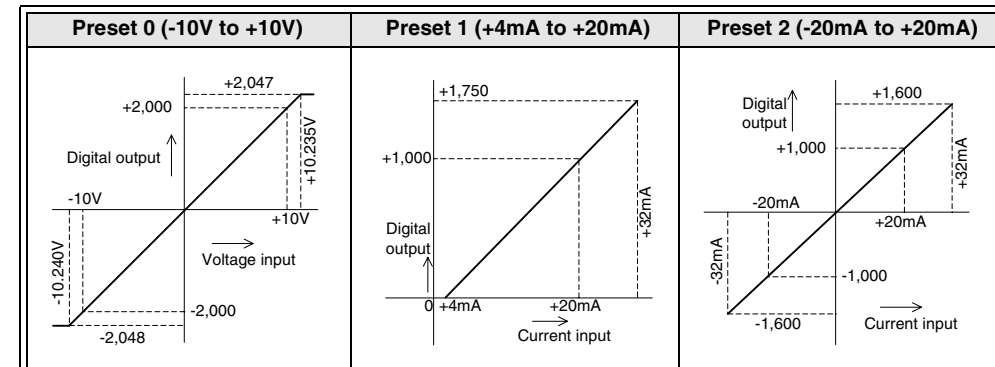

NOTE: Preset ranges are selected by an appropriate setting in the buffer memory of the analog block. Current/Voltage input selection must match the correct input terminal connections.

## 6. ALLOCATION OF BUFFER MEMORIES (BFM#)

### 6.1 Buffer memories

BFM	Contents								
*#0	Channel selection Default = H0000								
*#1	Channel 1	Contains the number of samples (1 to 4096) to be used for an averaged result. The default setting is 8- normal speed. High speed operation can be selected with a value of 1.							
*#2	Channel 2								
*#3	Channel 3								
*#4	Channel 4								
#5	Channel 1	These buffer memories contain the averaged input values for the number of samples entered for the channel in buffer memories #1 to #4 respectively.							
#6	Channel 2								
#7	Channel 3								
#8	Channel 4								
#9	Channel 1	These buffer memories contain the present value currently being read by each input channel.							
#10	Channel 2								
#11	Channel 3								
#12	Channel 4								
#13 - #14	Reserved								
#15	Selection of A/D conversion speed see note 2	When set to 0, a normal speed is selected of 15ms/ch (default) When set to 1, a high speed is selected of 6ms/ch							
#16 - #19	Reserved								
*#20	Reset to Defaults and Preset.	Default = 0							
*#21	Offset, Gain Adjust Prohibit.	Default = (0, 1) Permit							
*#22	Offset, Gain Adjust	b7	b6	b5	b4	b3	b2	b1	b0
		G4	O4	G3	O3	G2	O2	G1	O1
*#23	Offset Value	Default = 0							
*#24	Gain Value	Default = 5,000							
#25 - #28	Reserved								
#29	Error status								
#30	Identification code K2010								
#31	Cannot be used								

In buffer memory locations (BFMs) marked with an "\*" data can be written from the PLC using the TO instruction.

For buffer memories (BFMs) without "\*" mark, data can be read by the PLC using the FROM instruction.

Before reading from the analog special function block, ensure that the appropriate settings have been sent to the analog special function block. Otherwise, the previous values held in the analog block will be used.

The buffer memory also gives a facility to adjust the offset and gain via software.

Offset (intercept): The analog input value when the digital output becomes 0.

Gain (slope): The analog input value when the digital output becomes +1000.

#### 1) Channel Selection

Channel selection is made by a 4 character HEX number H0000 in buffer memory BFM #0. The least significant character controls channel 1 and the 4th character controls channel 4.

Setting of each character is as follows:

- O = 0: Preset range (-10V to +10V)
- O = 1: Preset range (+4mA to +20mA)
- O = 2: Preset range (-20mA to +20mA)
- O = 3: Channel OFF

Example: H3310

- CH1 : Preset range (-10V to +10V)
- CH2 : Preset range (+4mA to +20mA)
- CH3, CH4: Channel OFF

#### 2) Analog to Digital Conversion Speed Change

By writing 0 or 1 to BFM #15 of the FX2N-4AD, the speed at which A/D conversion is performed can be changed.

However the following points should be noted:

To maintain a high speed conversion rate, use the FROM/TO instructions as seldom as possible.

NOTE: When a conversion speed change is made, BFM #1-#4 are set to their default values immediately after the change. This is regardless of the values they held originally. Bear this in mind if a speed change will be made as part of the normal program execution.

#### 3) Adjusting Gain and Offset values

- a) When buffer memory BFM #20 is activated by setting it to K1, all settings within the analog special function block are reset to their default settings. This is a very quick method to erase any undesired gain and offset adjustments.
- b) If (b1, b0) of BFM #21 is set to (1,0), gain and offset adjustments are prohibited to prevent inadvertent changes by the operator. In order to adjust the gain and offset values, bits (b1, b0) must be set to (0,1). The default is (0,1).
- c) Offset and gain values of BFM #23 and #24 are sent respectively to the offset and gain resistors in non-volatile memory of the specified input channels. Input channels to be adjusted are specified by the appropriate G-O (gain-offset) bits of BFM #22. Example: If bits G1 and O1 are set to 1, input channel 1 will be adjusted when BFM #22 is written to by a TO instruction.
- d) Channels can be adjusted individually or together with the same gain and offset values.
- e) Offset and gain values in BFM #23 and #24 are in units of mV or mA. Due to the resolution of the unit the actual response will be in steps of 5mV or 20 mA.

#### 4) Status Information BFM #29

Bit devices of BFM #29	ON	OFF
b0 : Error	When any of b1 to b4 is ON. If any of b2 to b4 is ON, A/D conversion of all the channels is stopped.	No error
b1 : Offset/gain error	Offset/Gain data in the EEPROM is corrupted or adjustment error.	Offset/Gain data normal
b2 : Power source abnormality	24V DC power supply failure.	Power supply normal
b3 : Hardware error	A/D converter or other hardware failure.	Hardware Normal
b10 : Digital range error	Digital output value is less than -2048 or more than +2047	Digital output value is normal.
b11 : Averaging error	Number of averaging samples is 4097 or more or 0 or less (default of 8 will be used)	Averaging is normal. (between 1 and 4096)
b12 : Offset/gain adjust prohibit	Prohibit-(b1, b0) of BFM #21 is set to (1, 0)	Permit-(b1, b0) of BFM #21 is set to (0,1)

NOTE: b4 to b7, b9 and b13 to b15 are undefined.

#### 5) Identification Code BFM #30

The identification (or ID) code number for a Special Function Block is read using the FROM instruction.

This number for the FX2N-4AD Special Function Block unit is K2010.

The user's program in the PLC can use this facility in the program to identify the special function block before commencing data transfer from and to the special function block.



#### CAUTION

- Values of BFM #0, #23 and #24 are copied to the EEPROM memory of the FX2N-4AD. BFM #21 and BFM #22 are only copied when data is written to the gain/offset command buffer BFM #22. Also, BFM #20 causes the resetting of the EEPROM memory. The EEPROM has a life of about 10,000 cycles (changes), so do not use programs which frequently change these BFMs.
- Due to the time needed to write to the EEPROM memory, a delay of 300 ms is required between instructions that cause a write to the EEPROM. Therefore, a delay timer should be used before writing to the EEPROM for a second time.

## 7. DEFINING GAIN AND OFFSET

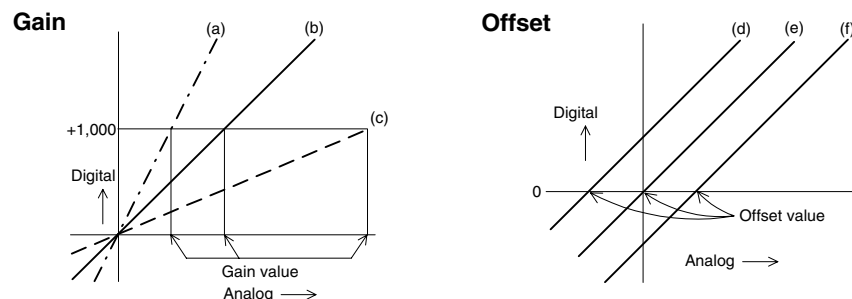

Gain determines the angle or slope of the calibration line, identified at a digital value of 1000.

- a) Small gain value: Large steps in digital readings
- b) Zero gain value: default (5V or 20mA)
- c) Large gain value: Small steps in digital readings

Offset is the 'Position' of the calibrated line, identified at a digital value of 0.

- d) Negative offset
- e) Zero offset: default (0V or 4mA)
- f) Positive offset

Offset and gain can be set independently or together. Reasonable offset ranges are -5V to +5V or -20mA to +20mA, and gain value - offset value = 1V to 15V or 4mA to 32mA. Gain and offset can be adjusted by software in the main unit (see program example 2)

- Bit device's b1, b2 of the gain/offset BFM #21 should be set to 0, 1 to allow adjustment.
- Once adjustment is completed these bit devices should be set to 1, 0 to prohibit any further changes.

## 8. EXAMPLE PROGRAM

### 8.1 Basic Program

In the following example, channels CH1 and CH2 are used as voltage inputs. The FX2N-4AD block is connected at the position of special function block No. 0. The number of averaged samples is set at 4 and data registers D0 and D1 of the main unit receive the averaged digital data.

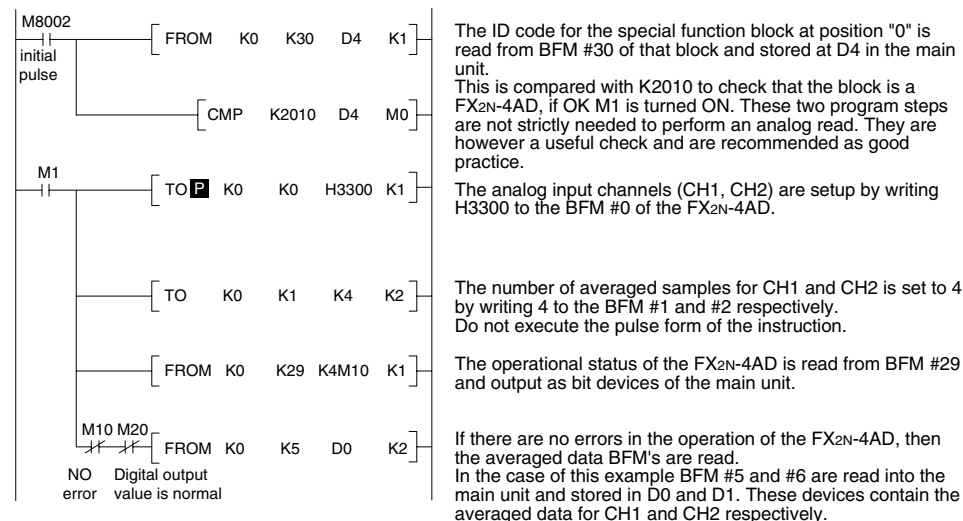

The ID code for the special function block at position "0" is read from BFM #30 of that block and stored at D4 in the main unit. This is compared with K2010 to check that the block is a FX2N-4AD, if OK M1 is turned ON. These two program steps are not strictly needed to perform an analog read. They are however a useful check and are recommended as good practice.

The analog input channels (CH1, CH2) are setup by writing H3300 to the BFM #0 of the FX2N-4AD.

The number of averaged samples for CH1 and CH2 is set to 4 by writing 4 to the BFM #1 and #2 respectively. Do not execute the pulse form of the instruction.

The operational status of the FX2N-4AD is read from BFM #29 and output as bit devices of the main unit.

If there are no errors in the operation of the FX2N-4AD, then the averaged data BFM's are read. In the case of this example BFM #5 and #6 are read into the main unit and stored in D0 and D1. These devices contain the averaged data for CH1 and CH2 respectively.

### 8.2 Using gain and offset in a program

The following is an example of changing the offset value on input channel CH1 to 0V and the gain value to 2.5V.

The FX2N-4AD block is in the position of block No. 0 (i. e. closest to the main unit).

Example: Adjusting gain/offset by PLC programming

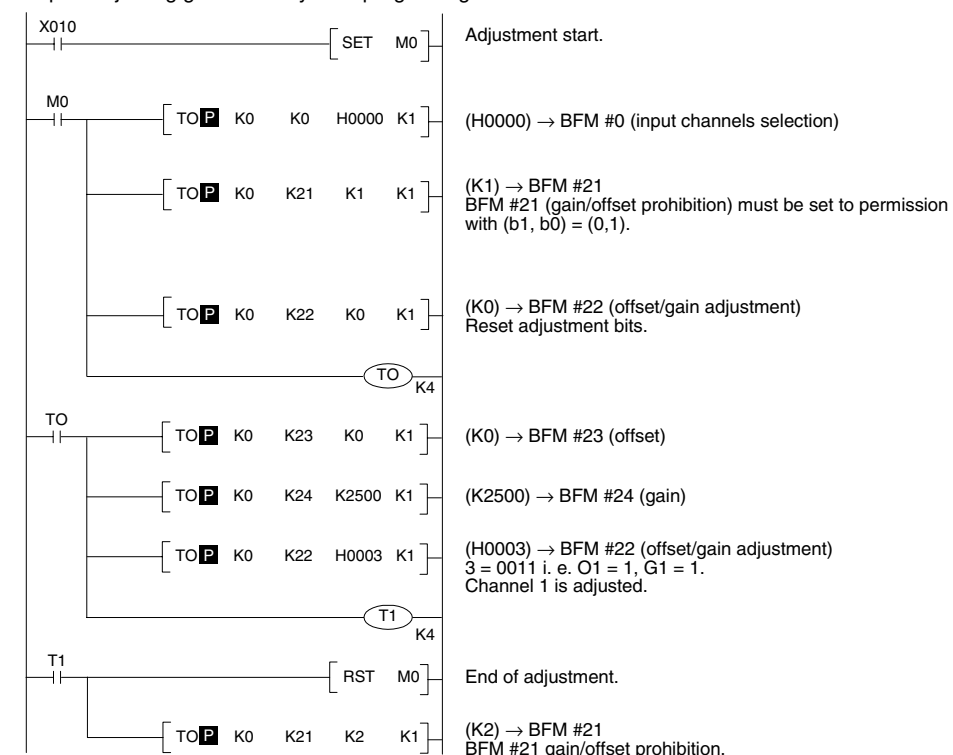

## 9. DIAGNOSTICS

### 9.1 Preliminary checks

- I. Check whether the input wiring and/or extension cables are properly connected on the FX2N-4AD analog special function block
- II. Check that the PLC system configuration limits have not been exceeded, i. e. the number of special function blocks, and the total system I/O are within the specified range.
- III. Ensure that the correct operating range has been selected for the application.
- IV. Check that there is no power overload on either the 5V or 24V power sources, remember the loading on a main unit or a powered extension unit varies according to the number of extension blocks or special function blocks connected.
- V. Make sure that the main unit has been switched to RUN.

### 9.2 Error checking

If the FX2N-4AD special function block does not seem to operate normally, check the following items.

- Check the status of the POWER LED.
  - Lit : The extension cable is properly connected.
  - Otherwise : Check the connection of the extension cable.
- Check the external wiring.
- Check the status of the "24V" LED (top right corner of the FX2N-4AD).
  - Lit : FX2N-4AD is OK, 24V DC power source is OK.
  - Otherwise : Possible 24VDC power failure, if OK possible FX2N-4AD failure.
- Check the status of the "A/D" LED (top right corner of the FX2N-4AD).
  - Lit : A/D conversion is proceeding normally.
  - Otherwise : Check buffer memory #29 (error status). If any bits (b2 and b3) are ON, then this is why the A/D LED is OFF.

This manual confers no industrial property rights or any rights of any other kind, nor does it confer any patent licenses. Mitsubishi Electric Corporation cannot be held responsible for any problems involving industrial property rights which may occur as a result of using the contents noted in this manual.

Manual number : JY992D65201

Manual revision : E

Date : September 2007



HEAD OFFICE : TOKYO BUILDING, 2-7-3 MARUNOUCHI, CHIYODA-KU, TOKYO 100-8310, JAPAN  
HIMEJI WORKS : 840, CHIYODA CHO, HIMEJI, JAPAN