

# mitsubishi

## High-Speed Counter Module

User's Manual  
(Hardware)

QD62-H01  
QD62-H02

Thank you for buying the Mitsubishi general-purpose programmable controller MELSEC-Q Series

Prior to use, please read both this manual and detailed manual thoroughly and familiarize yourself with the product.

**MELSEC-Q**  
Mitsubishi Programmable  
Controller

MODEL	QD62-H01/H02-U
MODEL CODE	13JY78
IB(NA)- 0800421-A(0807)MEE	

# ● SAFETY PRECAUTIONS ●

(Always read before starting use)

Before using this product, please read this manual and the relevant manuals introduced in this manual carefully and pay full attention to safety to handle the product correctly.

The instructions given in this manual are concerned with this product. For the safety instructions of the programmable controller system, please read the CPU module user's manual.

In this manual, the safety instructions are ranked as "DANGER" and "CAUTION".



**DANGER**

Indicates that incorrect handling may cause hazardous conditions, resulting in death or severe injury.



**CAUTION**

Indicates that incorrect handling may cause hazardous conditions, resulting in medium or slight personal injury or physical damage.

Note that the  **CAUTION** level may lead to a serious consequence according to the circumstances.

Always follow the instructions of both levels because they are important to personal safety.

Please keep this manual in a safe place for future reference and also pass this manual on to the end user.

## [DESIGN PRECAUTIONS]

### **DANGER**

- Depending on the malfunction of the external output transistor, there may be cases where the output is ON or OFF status. Install external monitoring circuitry for output signals that may lead to major accidents.

### **CAUTION**

- Do not bunch the control wires or communication cables with the main circuit or power wires, or install them close to each other.  
They should be installed 150 mm(5.9 inch) or more from each other.  
Not doing so could result in noise that may cause malfunction.

## [INSTALLATION PRECAUTIONS]

### CAUTION

- Use the programmable controller in an environment that meets the general specifications contained in the CPU user's manual to use.  
Using this programmable controller in an environment outside the range of the general specifications may cause electric shock, fire, malfunction, and damage to or deterioration of the product.
- When installing the module, securely insert the module fixing tabs into the mounting holes of the base module while pressing the installation lever located at the bottom of the module downward.  
Improper installation may result in malfunction, breakdown or dropping out of the module. Securely fix the module with screws if it is subject to vibration during use.
- Tighten the screws within the range of specified torque.  
If the screws are loose, it may cause fallout, short circuits, or malfunction.  
If the screws are tightened too much, it may cause damage to the screw and/or the module, resulting in fallout, short circuits or malfunction.
- Completely turn off the externally supplied power used in the system before mounting or removing the module.  
Not doing so could result in damage to the product.  
Not doing so may cause electric shock or damage to the module.
- Do not directly touch the conductive area or electronic components of the module.  
Doing so may cause malfunction or failure in the module.

## [WIRING PRECAUTIONS]

### CAUTION

- Perform correct pressure-displacement, crimp-contact or soldering for connector wire connections using the tools specified by the manufactures.  
Attach connectors to the module securely.
- Be careful not to let foreign matters such as sawdust or wire chips get inside the module.  
These may cause fires, failure or malfunction.
- The top surface of the module is covered with protective film to prevent foreign objects such as cable offcuts from entering the module when wiring.  
DO not remove this film until the wiring is complete.  
Before operating the system, be sure to remove the film to provide adequate heat ventilation.
- Be sure to fix communication cables or power supply cables leading from the module by placing them in the duct or clamping them.  
Cables not placed in the duct or without clamping may hang or shift, allowing them to be accidentally pulled, which may cause a module malfunction and cable damage.
- When removing the communication cable from the module, do not pull the cable. When removing the cable with a connector, hold the connector on the side that is connected to the module.  
Pulling the cable that is still connected to the module may cause malfunction or damage to the module or cable.
- Always ground the shielded cable on the encoder side (relay box).  
Otherwise, malfunction may occur.
- When wiring, be sure to verify the rated voltage of the product as well as the terminal layout. Fire or failure may result if incorrect voltage is input or incorrect wiring is performed.
- Connecting terminals with incorrect voltage may result in malfunction or mechanical failure.



# CONTENTS

1. Overview	1
2. Performance Specifications	2
3. Installation	4
3.1 Handling Precautions	4
3.2 Handling Environment	4
4. Part Names	5
5. External Wiring	6
5.1 Wiring Precautions	6
5.2 External Wiring	7
5.3 Intelligent Function Module Switch Settings	10
6. Comparison between QD62-H01/H02 and QD62	10
7. External Dimensions	11

## About the Manuals

The following manuals are also related to this product.  
Order them if necessary.

### Related Manuals

Manual name	Manual No. (Model code)
Model QD62, QD62E, QD62D High-Speed Counter Module User's Manual	SH-080036 (13JL95)

This manual describes only specifications of the QD62-H01/H02 that differ from the specifications of the QD62.

The manual mentioned above covers the usage of the QD62-H01/H02. When referring, replace the model name "QD62" with "QD62-H01/H02". For the details of differences between the QD62-H01/H02 and QD62, refer to Section 6.

### Conformation to the EMC Directive and Low Voltage Instruction

#### (1) For programmable controller system

To configure a system meeting the requirements of the EMC and Low Voltage Directives when incorporating the Mitsubishi programmable controller (EMC and Low Voltage Directives compliant) into other machinery or equipment, refer to Chapter 9 "EMC AND LOW VOLTAGE DIRECTIVES" of the QCPU User's Manual (Hardware Design, Maintenance and Inspection).

#### (2) For the product

No additional measures are necessary for the compliance of this product with the EMC and Low Voltage Directives.

## 1. Overview

This user's manual describes the specifications and the part names of the following modules that are used with the CPU module for MESLEC-Q series: Model QD62-H01 High-speed Counter Module (hereinafter referred to as QD62-H01), Model QD62-H02 High-speed Counter Module (hereinafter referred to as QD62-H02).

## 2. Performance Specifications

The following table shows the performance specifications of the high-speed counter modules:

Model		QD62-H01	QD62-H02	
Item		16 points (I/O assignment: Intelligent 16 points)		
Number of occupied I/O point		16 points (I/O assignment: Intelligent 16 points)		
Number of channels		2 channels		
Count input signal	Phase	1-phase input, 2-phase input		
	Signal level	5/12/24VDC, 2 to 5mA		
Counter	Counting speed (max) *1	1-phase input 50kPPS 2-phase input 50kPPS	1-phase input 10kPPS 2-phase input 7kPPS	
	Counting range	32-bit signed binary (-2147483648 to 2147483647)		
	Model	UP/DOWN Preset counter + Ring counter function		
	Minimum count pulse width (Duty ratio 50 %)	 (Unit: µs) <div style="border: 1px solid black; padding: 5px; display: inline-block;">           1-phase input 2-phase input         </div>	 (Unit: µs) (1-phase input)	 (Unit: µs) (2-phase input)
Coincidence output	Comparison range	32-bit signed binary		
	Comparison result	Setting value < Count value Setting value = Count value Setting value > Count value		
External input	Preset	5/12/24VDC, 2 to 5mA		
	Function start			
External output	Coincidence output	Transistor (sink type) output 2 points/channel, 12/24VDC 0.5A/point; 2A/common		
Applicable connectors		A6CON1 (Soldering type ,straight out) A6CON2 (Solderless type ,straight out) A6CON3 (Pressure welding type ,straight out) A6CON4 (Soldering type ,usable for straight out and diagonal out)		
5VDC internal current consumption		0.30A		
Weight		0.11kg		

\*1: Counting speed is affected by pulse rise and fall time. Possible counting speeds are shown in the following table. Note that a miscount may occur if the D62-H01 counts a pulse larger than  $t=50\mu\text{s}$ . In this case, use the QD62-H02.



Model	QD62-H01		QD62-H02	
Counting speed switch settings	1-phase input	2-phase input	1-phase input	2-phase input
t = 5 $\mu$ s or less	50kPPS		10kPPS	7kPPS
t = 50 $\mu$ s	5kPPS		—	
t = 500 $\mu$ s	—		500PPS	250PPS

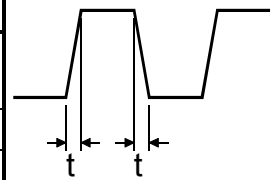

#### Remarks

For general specifications of the QD62-H01 and QD62-H02, refer to the user's manual for the CPU module used.

## 3. Installation

### 3.1 Handling Precautions

This section describes the precautions on handling the module.

- 1) Do not drop or give a strong impact to the module case and/or connector.
- 2) Do not remove the printed-circuit board of the module from the case.  
Doing so may cause a failure.
- 3) Be careful to prevent foreign matters such as cutting chips or wire chips from entering the module.  
Failure to do so may cause a fire, failure or malfunction.
- 4) A protective film is attached to the module top to prevent foreign matter such as wire chips from entering the module during wiring.  
Do not remove the film during wiring.  
Be sure to remove it for heat dissipation before system operation.
- 5) Tighten the module fixing screws within the following specified torque range.  
Insufficient tightening torque could result in a drop, short circuit or malfunction.  
Excessive tightening may damage the screw and/or the module, resulting in a drop, short circuit or malfunction.

Screw	Tightening torque range
Module fixing screw (M3 screws) *1	0.36 to 0.48 N·m
Conenector screw of module (M2.6 screws)	0.20 to 0.29 N·m

\*1 The module can be easily fixed onto the base unit using the hook at the top of the module.

However, it is recommended to secure the module with the module fixing screws if the module is subject to significant vibration or shock.

- 6) When mounting the module to the base unit, insert the module fixing projection into the fixing hole in the base unit, and mount the module using the hole as a supporting point.  
Incorrect module mounting may cause a malfunction, failure, or drop of the module.

### 3.2 Installation Environment

For further details, refer to the user's manual for the CPU module used.

## 4. Part Names

This section describes the name of each part of the high-speed counter module.

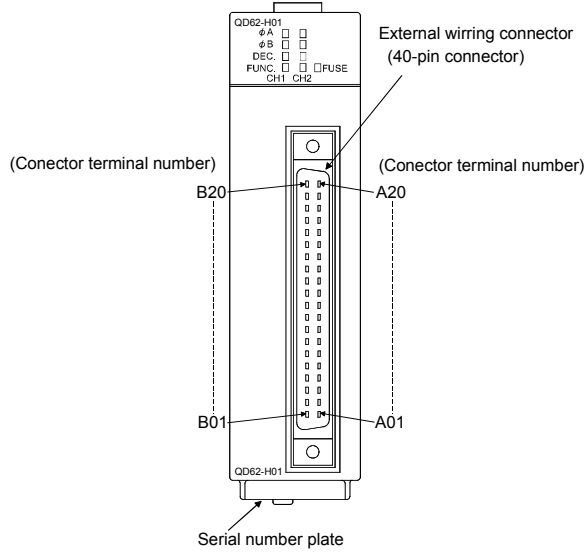

LED name	Description
$\phi A$	On: Voltage is being applied to the Phase A pulse input terminal.
$\phi B$	On: Voltage is being applied to the Phase B pulse input terminal.
DEC.	On: Counter is in the process of subtraction.
FUNC.	On: Voltage is being applied to the function start input terminal.
FUSE	On: Voltage is being applied to the external power supply input terminal while the fuse in the coincidence signal output section is broken.

\*: The external appearance of the QD62-H02 is the same as that of the QD62-H01, except for the model name.

Terminal number		QD62-H01/H02
CH1	CH2	Signal name
A20	A13	Phase A pulse input 24V
B20	B13	Phase A pulse input 12V
A19	A12	Phase A pulse input 5V
B19	B12	ABCOM
A18	A11	Phase B pulse input 24V
B18	B11	Phase B pulse input 12V
A17	A10	Phase B pulse input 5V
B17	B10	Preset input 24V
A16	A09	Preset input 12V
B16	B09	Preset input 5V
A15	A08	CTRLCOM
B15	B08	Function start input 24V
A14	A07	Function start input 12V
B14	B07	Function start input 5V
A06	A05	EQU1 (Coincidence output point No. 1)
B06	B05	EQU2 (Coincidence output point No. 2)
A04	A03	NC
B04	B03	NC
A02	A01	0 V
B02	B01	12/24V

## 5. External Wiring

### 5.1 Wiring Precautions

- 1) Different terminals have been prepared for connection depending on the voltage of the input signal. Connecting a terminal of incorrect voltage may result in malfunction or mechanical failure.
- 2) For 1-phase input, always perform pulse input wiring on the Phase A side.
- 3) When pulse status noise is input, the QD62-H01/H02 may miscount.
- 4) Provide the following measures against noise for high-speed pulse input:
  - a) Always use a shielded twisted pair cable and provide grounding.
  - b) Avoid placing the shielded twisted pair cable parallel to wires that have large amounts of noise such as power cables or input/output cables. Place the cable at least 150mm (5.9 inch) from such wires and perform wiring using the least distance as possible.
- 5) An example of wiring incorporating measures against noise is shown below:

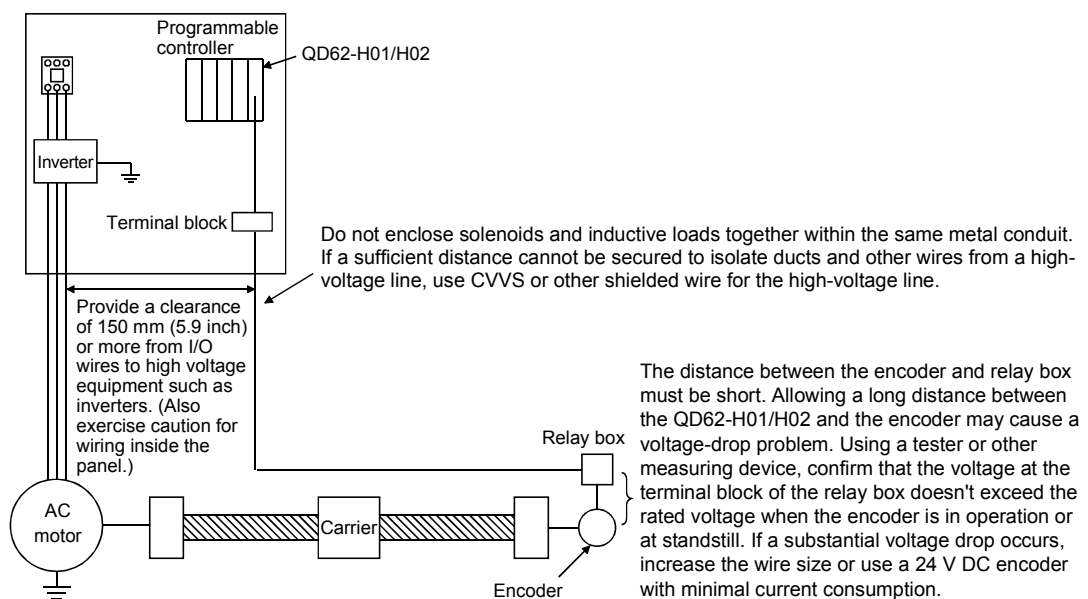

- Grounding the shielded twisted pair cable is performed on the encoder side (relay box). (This example shows connection with 24 V sink load.)

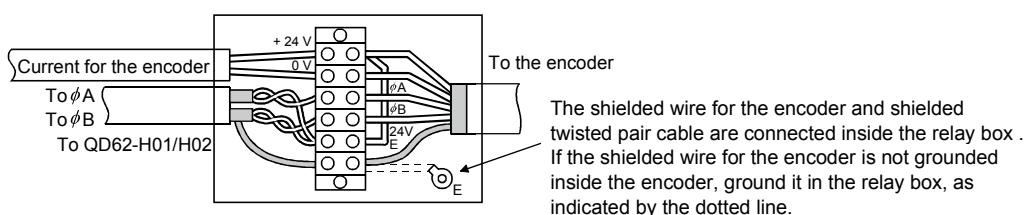

## 5.2 External Wiring

### 1) Wiring example of a module and an encoder

#### a) Wiring example with an open collector output type encoder (24VDC)

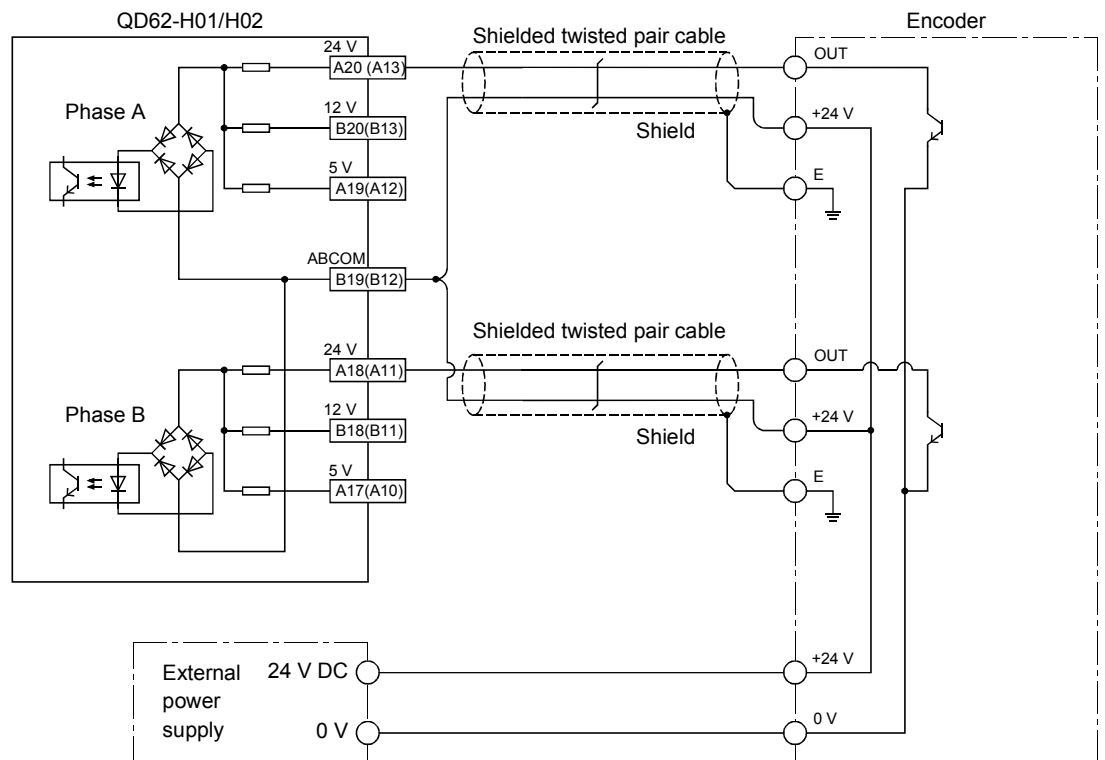

The terminal number in parentheses is for Channel 2.

### POINT

When wiring the QD62-H01/H02 and the encoder, separate the power supply cable and signal cable line.

The following diagram figure shows an example.

[Wiring example]

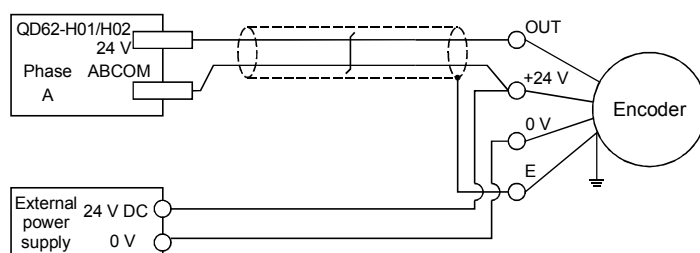

[Incorrect wiring example]

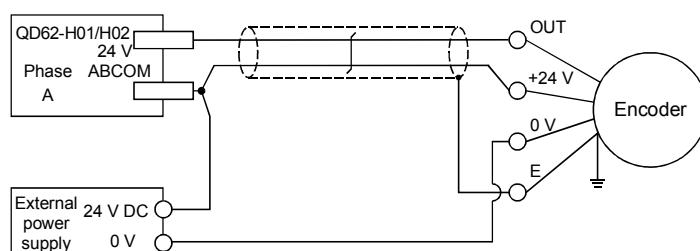

The current flows through the shielded twisted pair cable in the same direction, so there is no cancelling effect. This makes it more prone to electromagnetic induction.



When the controller (source loading type) is 5VDC:

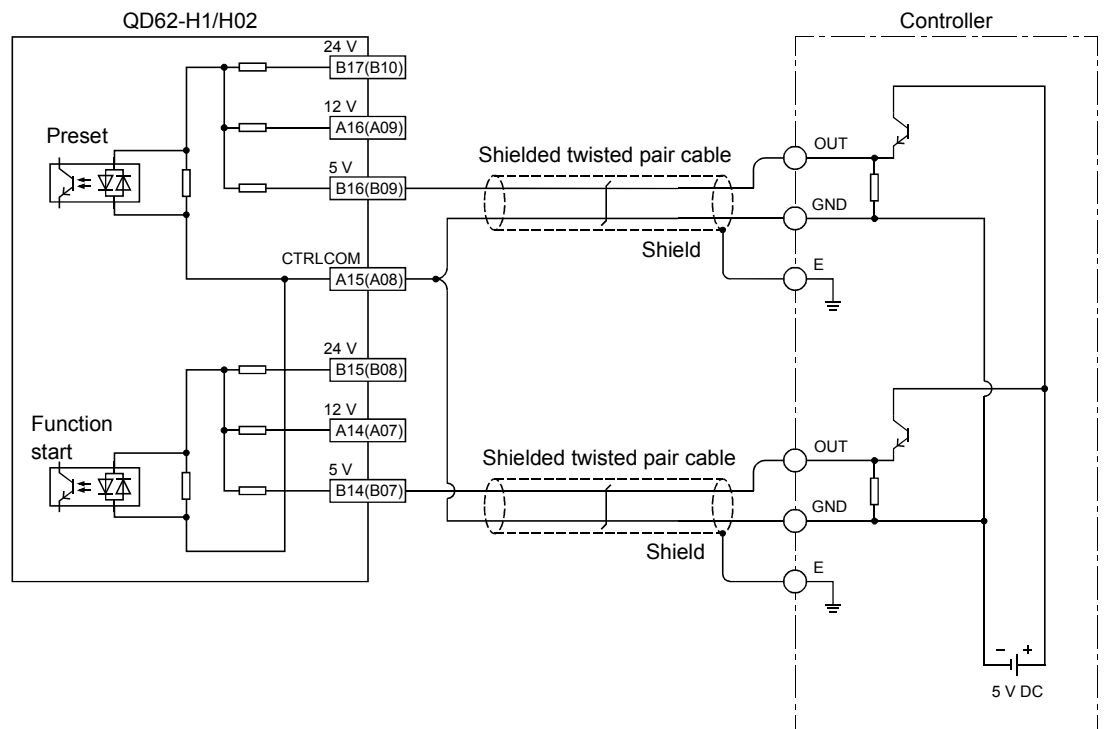

The terminal number in parentheses is for Channel 2.

### 3) Wiring example with an external output terminal

When the coincidence output (EQU terminal) is used, an external power supply of 10.2 to 30VDC will be required for operation of the internal photocoupler.

A wiring example is shown below.

a) For QD62-H01/H02 (Sink output type)

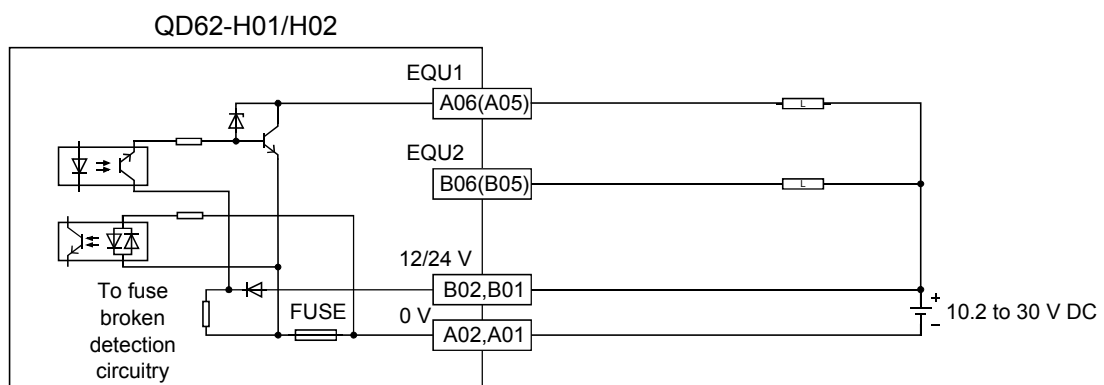

The terminal number in parentheses is for Channel 2.

### 5.3 Intelligent Function Module Switch Settings

The intelligent function module switch settings are performed using the I/O assignment settings of the GX Developer.

	Setting item
Switch 1 (for Channel 1)	
Switch 2 (for Channel 2)	
Switch 3	Reserved
Switch 4	Reserved
Switch 5	Reserved

## 6. Comparison between QD62-H01/H02 and QD62

This section describes the differences between the QD62-H01/H02 and QD62.

### 1) Specifications comparison

- Maximum counting speed (Refer to Chapter 2.)
- Minimum count pulse width (Refer to Chapter 2.)
- Pulse rise time (Refer to Chapter 2.)
- Counting speed setting in the intelligent function module switch settings (Refer to Section 5.3.)

The same specifications apply for the QD62-H01/H02 and QD62, excluding those described above.

When the manual for the QD62 is referred for the QD62-H01/02, use the specifications in this manual as for the items described above.

### 2) GX Configurator CT

In GX Configurator CT, the “QD62-H01” and “QD62-H02” are not displayed in the Module model name field.

Select the “QD62” for a model name.



### 3) GX Developer

GX Developer does not support the display of the model names for the QD62-H01/H02.

GX Developer displays the “QD62” as the model name for the QD62-H01/H02.

## 7. External Dimensions

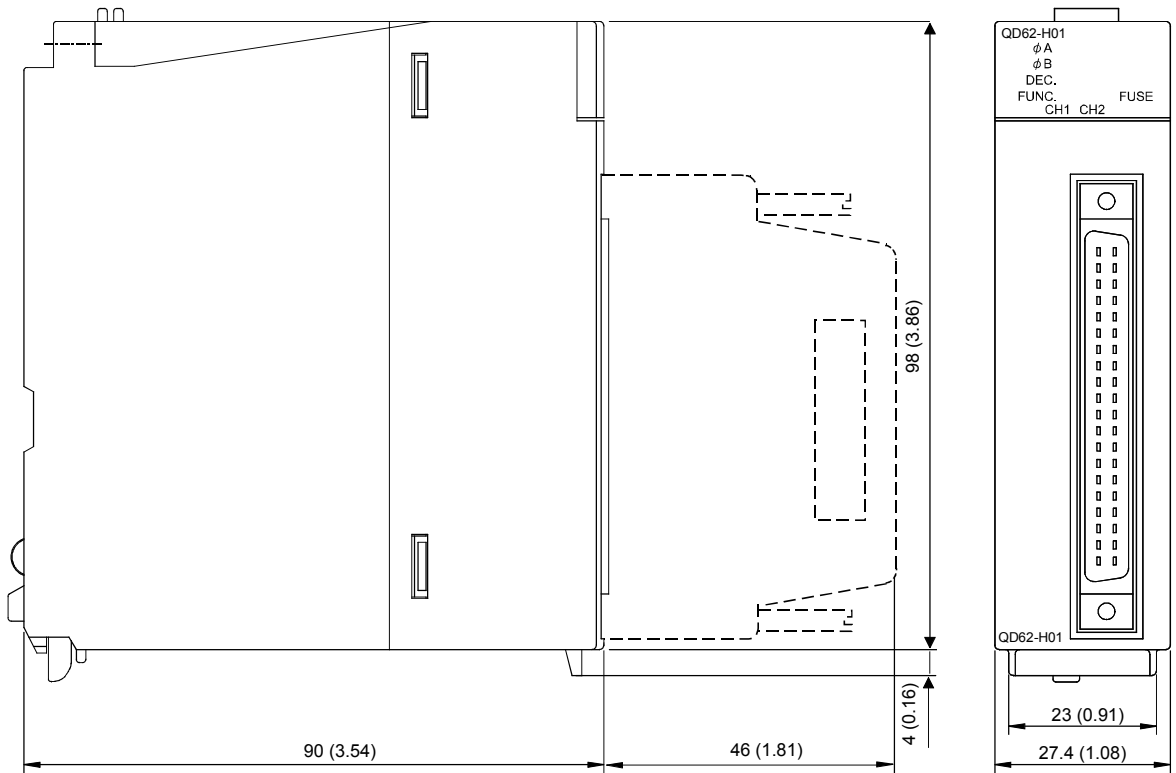

Unit:mm(inch)

## Warranty

Mitsubishi will not be held liable for damage caused by factors found not to be the cause of Mitsubishi; machine damage or lost profits caused by faults in the Mitsubishi products; damage, secondary damage, accident compensation caused by special factors unpredictable by Mitsubishi; damages to products other than Mitsubishi products; and to other duties.

### For safe use

- This product has been manufactured as a general-purpose part for general industries, and has not been designed or manufactured to be incorporated in a device or system used in purposes related to human life.
- Before using the product for special purposes such as nuclear power, electric power, aerospace, medicine or passenger movement vehicles, consult with Mitsubishi.
- This product has been manufactured under strict quality control. However, when installing the product where major accidents or losses could occur if the product fails, install appropriate backup or failsafe functions in the system.

Country/Region	Sales office/Tel	Country/Region	Sales office/Tel
U.S.A	Mitsubishi Electric Automation Inc. 500 Corporate Woods Parkway Vernon Hills, IL 60061, U.S.A. Tel : +1-847-478-2100	Hong Kong	Mitsubishi Electric Automation (Hong Kong) Ltd. 10th Floor, Manulife Tower, 169 Electric Road, North Point, Hong Kong Tel : +852-2887-8870
Brazil	MELCO-TEC Rep. Com.e Assessoria Tecnica Ltda. Rua Correia Dias, 184, Edificio Paraiso Trade Center-8 andar Paraiso, Sao Paulo, SP Brazil Tel : +55-11-5908-8331	China	Mitsubishi Electric Automation (Shanghai) Ltd. 4/F Zhi Fu Plazz, No.80 Xin Chang Road, Shanghai 200003, China Tel : +86-21-6120-0808
Germany	Mitsubishi Electric Europe B.V. German Branch Gothaer Strasse 8 D-40880 Ratingen, GERMANY Tel : +49-2102-486-0	Taiwan	Setsuyo Enterprise Co., Ltd. 6F No.105 Wu-Kung 3rd.Rd, Wu-Ku Hsiang, Taipei Hsine, Taiwan Tel : +886-2-2299-2499
U.K	Mitsubishi Electric Europe B.V. UK Branch Travellers Lane, Hatfield, Hertfordshire., AL10 8XB, U.K. Tel : +44-1707-276100	Korea	Mitsubishi Electric Automation Korea Co., Ltd. 1480-6, Gayang-dong, Gangseo-ku Seoul 157-200, Korea Tel : +82-2-3660-9552
Italy	Mitsubishi Electric Europe B.V. Italian Branch Centro Dir. Colleoni, Pal. Perseo-Ingr.2 Via Paracelso 12, I-20041 Agrate Brianza., Milano, Italy Tel : +39-039-60531	Singapore	Mitsubishi Electric Asia Pte, Ltd. 307 Alexandra Road #05-01/02, Mitsubishi Electric Building, Singapore 159943 Tel : +65-6470-2460
Spain	Mitsubishi Electric Europe B.V. Spanish Branch Carretera de Rubi 76-80, E-08190 Sant Cugat del Valles, Barcelona, Spain Tel : +34-93-565-3131	Thailand	Mitsubishi Electric Automation (Thailand) Co., Ltd. Bang-Chan Industrial Estate No.111 Moo 4, Serithai Rd, T.Kannayao, A.Kannayao, Bangkok 10230 Thailand Tel : +66-2-517-1326
France	Mitsubishi Electric Europe B.V. French Branch 25, Boulevard des Bouvets, F-92741 Nanterre Cedex, France TEL: +33-1-5568-5568	Indonesia	P.T. Autoteknindo Sumber Makmur Muara Karang Selatan, Block A/Utara No.1 Kav. No.11 Kawasan Industri Pergudangan Jakarta - Utara 14440, P.O.Box 5045 Jakarta, 11050 Indonesia Tel : +62-21-6630833
South Africa	Circuit Breaker Industries Ltd. Private Bag 2016, ZA-1600 Isando, South Africa Tel : +27-11-928-2000	India	Messung Systems Pvt, Ltd. Electronic Sadan NO:III Unit No15, M.I.D.C Bhosari, Pune-411026, India Tel : +91-20-2712-3130
		Australia	Mitsubishi Electric Australia Pty. Ltd. 348 Victoria Road, Rydalmere, N.S.W 2116, Australia Tel : +61-2-9684-7777

## MITSUBISHI ELECTRIC CORPORATION

HEAD OFFICE : TOKYO BUILDING, 2-7-3 MARUNOUCHI, CHIYODA-KU, TOKYO 100-8310, JAPAN  
NAGOYA WORKS : 1-14, YADA-MINAMI 5-CHOME, HIGASHI-KU, NAGOYA, JAPAN

When exported from Japan, this manual does not require application to the Ministry of Economy, Trade and Industry for service transaction permission.

Specifications subject to change without notice.